



ON-/OFFSHORE

Hydraulic Part-Turn Actuator





We Turn the World for You

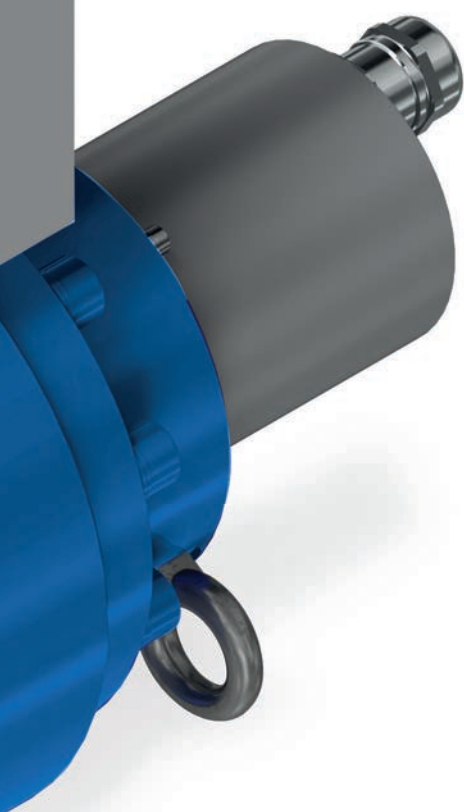

We put you in the best position

We have developed the rotary actuators presented here, which have proven their worth through many years of use, especially for fittings, butterfly valves and ball valves.

The highest safety and quality demands as well as longevity and precision are typical features of HKS rotary actuators. Our strengths also include ATEX, DIN standards or special customised solutions.

Wherever materials need to be rotated and tilted, precisely accelerated, braked, positioned and held, HKS products are there to help you get the job done – with great precision and endurance. We see the “made in Germany” seal as the highest standard and the yardstick for the quality of our products at the same time. Innovation is an integral part of everything we do, which is an advantage for you, as with HKS products you can always be sure of working with state-of-the-art technology. HKS has its own development department and manufactures practically every part in-house, enabling us to provide you with everything you need in outstanding quality.

The outstanding quality of our rotary actuators is internationally recognised and based on our innovative developments, the use of best-quality materials, and production with utmost precision. We achieve optimum results for use all sectors.

Typical applications



Water works
Sewage works
Steel constructions for hydraulic engineering
Drinking water distribution



Chemicals and pharmaceuticals industry
HVAC industry
Shipbuilding
Steel mills
Food industry



Exploration, offshore facilities
Refineries
Pipelines
Tank farms



Geothermal power plants
Solar thermal power plants
Biogas power plants
Power plants (water, coal, gas, oil, atomic)

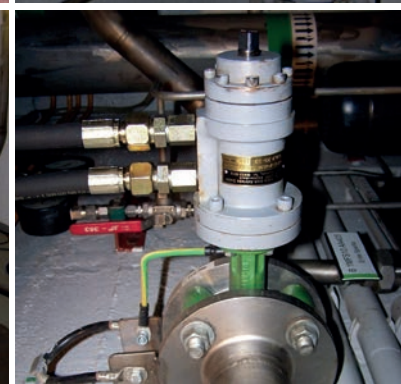

Functional description

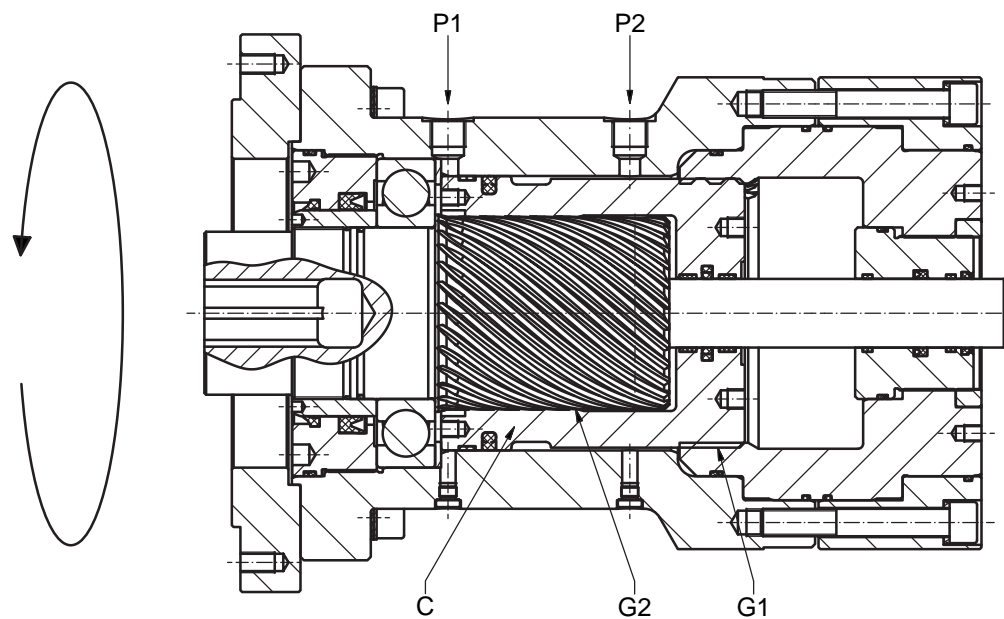

The oil pressure which is supplied through connections P1 and P2 causes a rotary movement on the actuator shaft. The linear movement of the piston C is converted into a rotary movement by means of multiple gears. (Sectional representation as from the series SA-H 125)

With pressure at P1 the actuator shaft rotates, from the basic position to the left (anti clockwise). Changes in the direction can be especially made to order.

Part-turn actuator

Electro-hydraulic

Certification: ATEX - Ex II2G EEx d IIB T4

Protection cat: IP 65

Temperature range: -25 to +55°C

Position accuracy: < 2% of full scale

Power-up time: ≤ S3-10%

Functions:

OPEN / CLOSE

Positioning

Fail Safe hydraulically (storage)

Fail Safe mechanically (spring)



Industrial automation means efficiency

The newly developed electrohydraulic actuators for fittings satisfy these high requirements on flexible, automated industrial fittings. The sturdy, compact and modular design offers ideal solutions for special requirements

- › Oil and gas
- › Chemicals and petrochemicals
- › Energy and water industry

Your customer benefits

- › Compact design
- › Integrated safety functions
- › Low installation and operating costs

An installation with no piping, the use of top-quality components and a 100% functional test vouch for the operational safety and reliability of these systems. The pressure-resistant encapsulation of all electrical components in one housing also allows their use in potentially explosive areas (ATEX) and at the same time guarantees a high degree of protection under extreme working conditions:

- › Explosion protection
- › High reliability

Rotary lift combination

Plug valves / Electro-hydraulic



up to 160 bar



up to 16.000 Nm



up to 360°

Lift up to 1,200mm

Lifting power up to 360,000 N

Tensile force up to 180,000 N

Higher lifting power and tensile force on request



In the series with the linear unit in front of the rotary actuator (**DHK-H-ZV**) the lifting cylinder and rotary actuator are connected by flanges.

The spline tothing on the drive shaft of the rotary actuator interlocks with the bore of the lifting cylinder's piston rod.

The spline and bore are manufactured with a corresponding length or depth depending on the length of stroke. The drive shaft with two opposite feather keys is located at the end of the piston rod.

The lifting and turning movements can be carried out synchronously or separately. An exact positioning of the movements can be achieved with accessory parts.

Powerpack

Hydraulic

From SA-H 55 to SA-H 140

Torque up to 7.000 Nm

Protection cat: IP 68

Aggregat: ZB 1632, compl. version for double and single acting actuators

Power-up time: S3 10 %

Delivery volume: 0.4 l/min

Absorption: 400 cm³

Electromotor: 230 VA C one phase with operation condenser

Emergency operation

E Box

Electronically / hydraulically controlled

Functions:

Open/close

Positioning

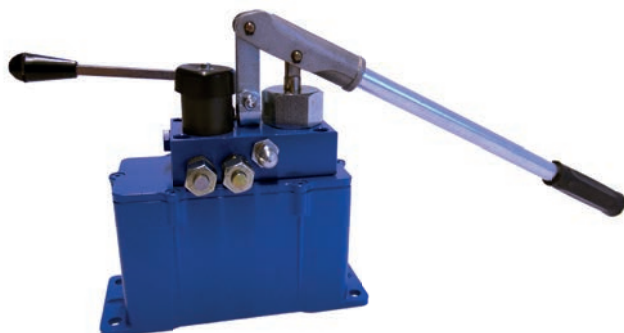

Hand pump

Type GL290-25

Tank capacity: 2.2 l (optional with 4 l)

Delivery: 25 cm³

Working pressure up to: 180 bar

Weight: 7,5 kg

Material: Aluminium pump head, casted aluminium tank



SA-H1

Solo Part-turn actuator (Helical principle)

Typical features

- › Small dimensions
- › All sliding surfaces are hardened machine-ground and polished
- › Identical torque in both directions
- › Interchangeable types of mounting
- › No Internal leakage so that intermediate positions can be exactly maintained
- › Variable positioning of the drive shaft
- › Interchangeability of all components
- › Suitable for almost all pressure media
- › Endposition cushioning for all movement is possible



 up to 210 bar

 up to 250.000 Nm

 up to 90° ±1

Temperature range: -10°C to 75°C

Protection cat: IP 65 / IP 68

More features

- › ISO 5211 Flange and additional standard and special flanges possible
- › Emergency operation
- › Special angle possible
- › Ability to position precisely
- › Safe, stable and compact housing design in nodular graphite iron
- › Floating time fail-safe open/closed: <1 sec. (depending on the size of the actuator)
- › Certification: ATEX, SIL2
- › Seals: PU / NBR / Viton
- › Power-up time: S1 100 %
- › Hydraulic fluid: HLP DIN 51524 HFC and HFD possible on request
- › low maintenance
- › Materials: steel, nodular graphite iron, stainless steel on request

- › Sealing material from reputable manufacturers
- › High-quality and high-tensile materials are used
- › Piston end position can be indicated by proximity switches
- › Various auxiliary attachments available
- › Angle of rotation can be indicated by digital or analog angle sensor
- › Special requests to your satisfaction
- › Short delivery periods
- › Favourable price-performance ratio

SA-H2

Solo Part-turn actuator (Helical principle)



up to 125 bar



up to 10.000 Nm



up to 90° ±1

Temperature range: -10°C to 75°C

Protection cat: IP 65 / IP 68

Face mounting

More features

- › ISO 5211 Flange and additional standard and special flanges possible
- › Emergency operation
- › Special angle possible
- › Ability to position precisely
- › Safe, stable and compact housing design in nodular graphite iron
- › Floating time fail-safe open/closed: <1 sec. (depending on the size of the actuator)
- › Certification: ATEX, SIL2
- › Seals: PU / NBR / Viton
- › Power-up time: S1 100 %
- › Hydraulic fluid: HLP DIN 51524 HFC and HFD possible on request
- › low maintenance
- › Materials: steel, nodular graphite iron, stainless steel on request

AFR

Hydraulic / Spring Return

Part-Turn actuator spring return

You can still obtain our part-turn actuators provided with a **spring return**. These have been designed for operation in a one-sided hydraulic system. The part-turn actuator normally opens the closed armature by hydraulic pressure and it closes with a spring return. The opposite is achieved with appropriate assembly. Depending on the assembly the 'open' or 'closed' position can be maintained. Specific customer requirements are taken into account here.



up to 350 bar



up to 38.000 Nm



Spring reset single-acting

Opening moment up to 38,000 Nm

Closing moment up to 7,000 Nm

Safety function through spring reset

More features

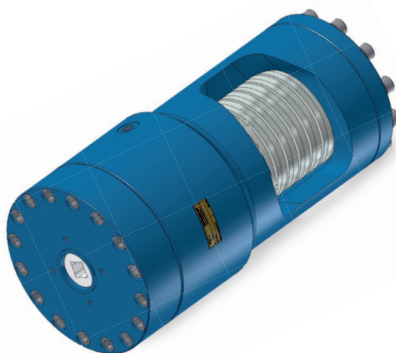

- › ISO 5211 flange and additional standard and special flanges possible
- › Emergency operation
- › Special angle possible
- › Ability to position precisely
- › Certification: ATEX, SIL2
- › Seals: PU / NBR / Viton
- › Low maintenance
- › Protection cat: IP 65 / IP 68
- › Hollow Shaft squars
- › Hollow Shaft double
- › Hollow Shaft 1 feather key slot
- › Hollow Shaft 2 feather key slots



Rack and Pinion actuators

Typical features of Rack and Pinion actuators

- › Maximum torque
- › Short axial overall length
- › Very short angle play
- › Extremely sturdy



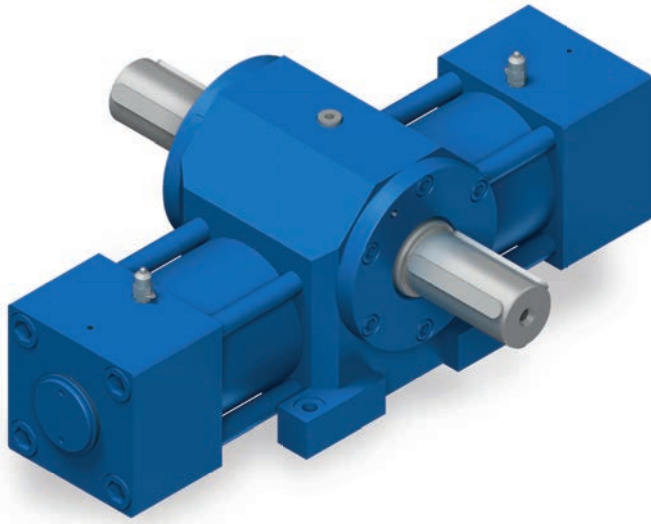

DEK

 up to 200 bar

 up to 40.000 Nm

 up to 720°

Flange or foot fixing

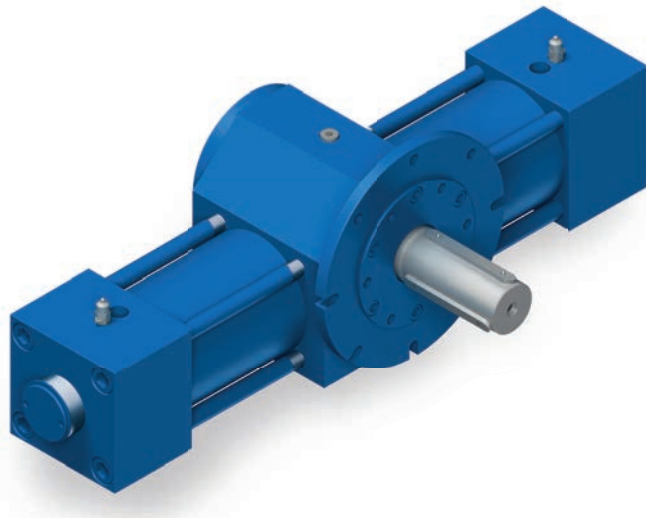

DEK1

 up to 200 bar

 up to 60.000 Nm

 up to 360°

Flange or foot fixing

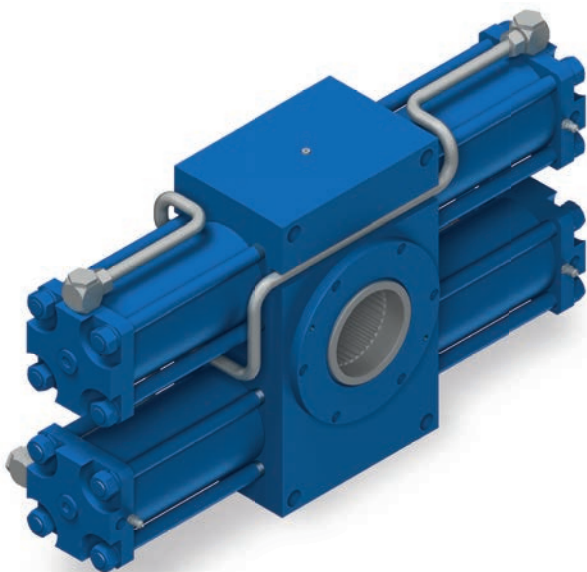

DZK

 up to 200 bar

 up to 350.000 Nm

 up to 360° (bigger on request)

Flange or foot fixing

Technical data

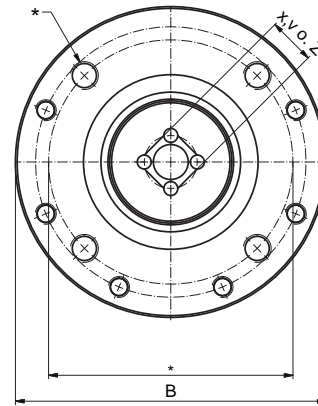

View

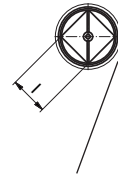

Mark
open / closed

Typ SA-H P _{max} =210bar		30	42	55	63	80	100	125
M _{nom} /P _{working} Nm/bar		0,3	0,95	2,1	3,0	7,2	14,7	22
Absorbition volume	cdm	0,009	0,022	0,038	0,081	0,164	0,366	0,484
Weight	kg	5,6	6,9	8,2	12,0	20,6	27,7	47,0
B	mm	70	114	124	128	150	178	222
O	mm	11	18	18	25	25	31	37
P	mm	99	137	159	187	216	252	285
P ₁	mm	114	157	179	208	236	272	305
S	"	G1/8	G1/8	G1/4	G1/4	G3/8	G3/8	G3/8
T	mm	10	15	20	25	25	25	25
N	mm	10	15	15	15	15	15	15
I	mm	6	12	17	17	22	22	22
HWP X1 ^{H7} _(max.)	mm	12	18	20	22	30	42	55
	mm*	12	18	18	22	28	42	50
X2	mm	4	6	6	6	8	12	16
X3	mm	7,8	11,8	12,8	12,8	18,3	24,3	31,8
HX	mm	31	39	45	45	75	100	120
	mm	30	35	45	45	65	80	110
HWV SW V _(max.)	mm	12	17	18	22	27	36	50
	mm*	11	17	17	22	27	36	46
HV	mm	34	34	45	45	50	50	50
	mm	16	19	24	29	38	48	48
HWZ SW Z _(max.)	mm	10	12	14	17	22	30	36
	mm*	9	11	14	17	22	27	36
Z1	mm	17	24	25	25	36	50	71
HZ	mm	34	34	45	48	50	64	64
	mm*	19	30	34	48	48	64	64

*) Dimensions acc. DIN ISO 5211

Emergency operation

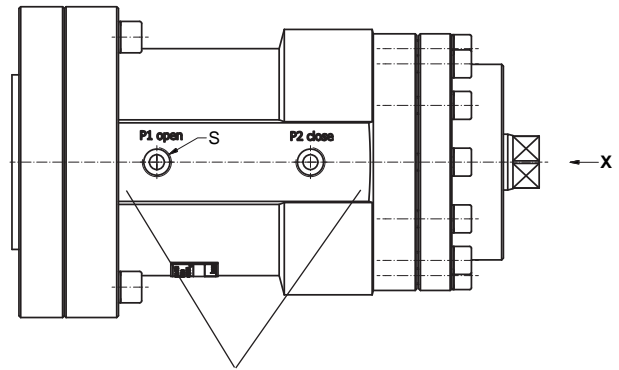
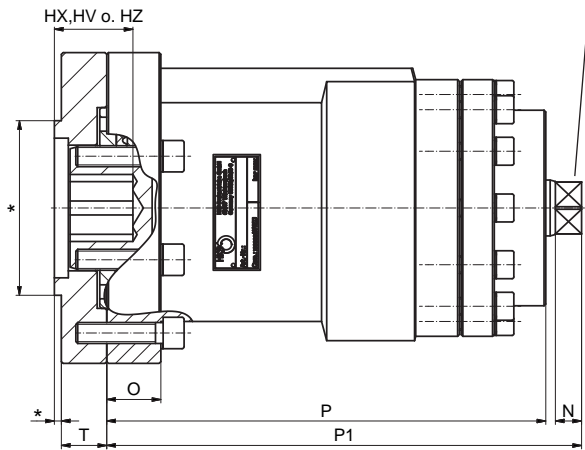

Hole pattern for valve assembly. Adapter plate or direct assembly on request.

140	160	180	200	225	225S	250	280	300
30	50	71	100	142	175	200	275	350
0,719	1,099	1,626	2,179	3,271	4,039	4,532	6,268	7,843
74,0	114	150	194	354	462	551	764	1100
250	278	298	325	385	385	450	490	555
40	43	45	54	64	64	90	100	110
304	365	435	440	570	690	710	790	840
324	385	455	460	590	710	730	810	860
G3/8	G3/8	G1/2	G1/2	G3/4	G3/4	G1	G1	G1
25	25	25	30	40	45	50	50	50
15	15	15	15	15	15	15	15	15
22	22	22	22	22	22	22	22	22
60	75	75	95	100				
60	72	72	80	98	100	110	120	140
18	20	20	25	28	28	28	32	36
34,4	42,4	42,4	52,9	56,4	56,4	61,4	67,4	78,4
120	150	150	175	175				
110	130	130	180	180	175	175	200	200
50	67	75	82	82				
46	55	75	75	75	82	95	104	120
57	60	60	77	77				
57	57	57	77	77	75	85	90	100
41	55	55	65	75				
36	55	55	55	75	70	80	85	95
71	95	95	116	116	116	135	138	170
64	64	82	82	82				
64	64	82	82	82	75	85	90	100

Various connection

HWP

with 2 feather key slots DIN 6885

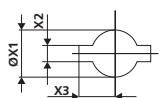

HWP 1

with 1 feather key slot DIN 6685

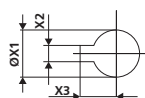

HWV

ISO-Square DIN 475T1

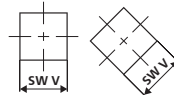

HWZ

ISO-Double DIN 475T1

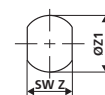

Nom. torque

to working pressure of the series

SA-H 30 to SA-H 300

SA-H 30

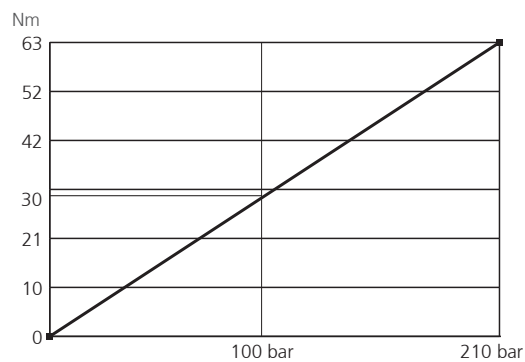

SA-H 42



SA-H 55



SA-H 63

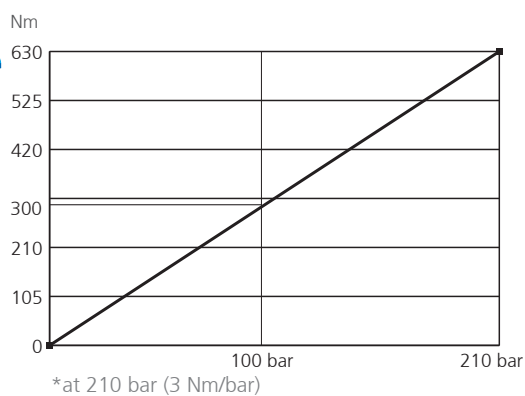

SA-H 80



SA-H 100



SA-H 125

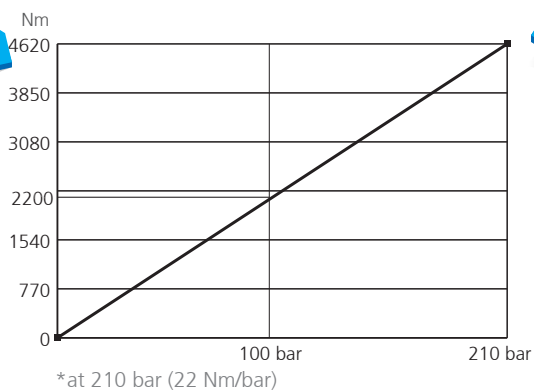

SA-H 140



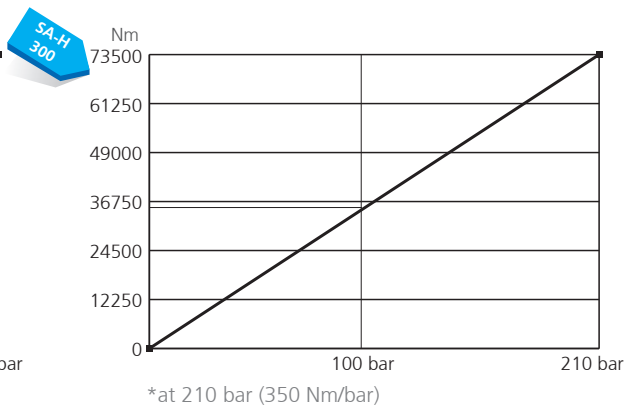
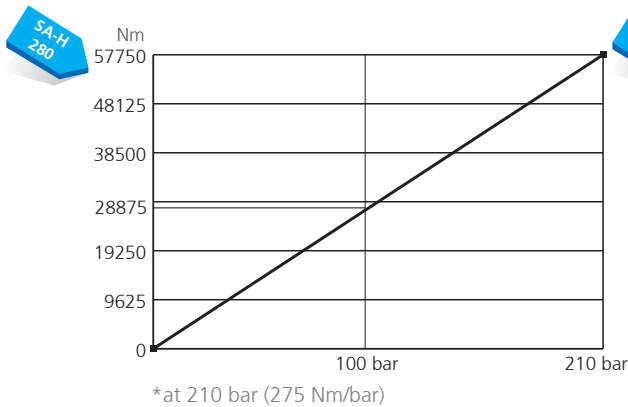
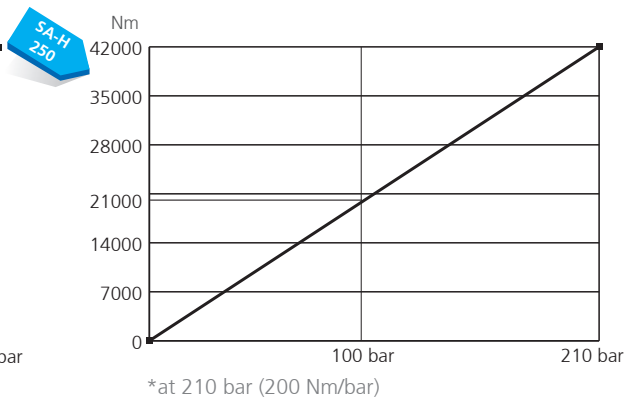
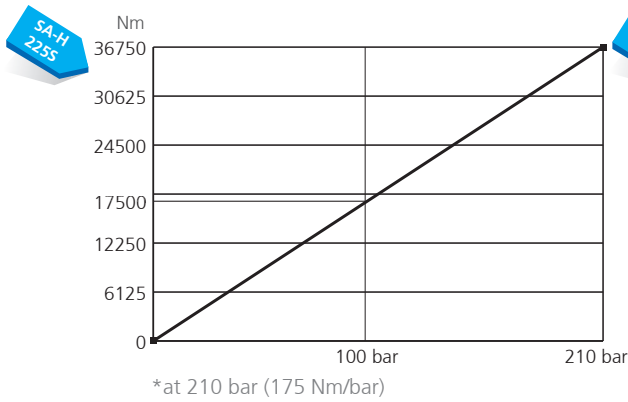
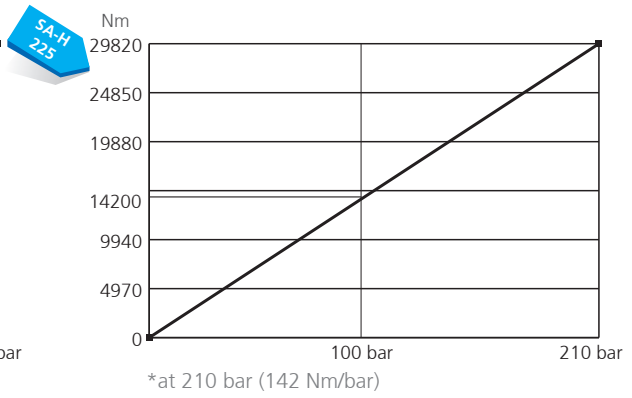
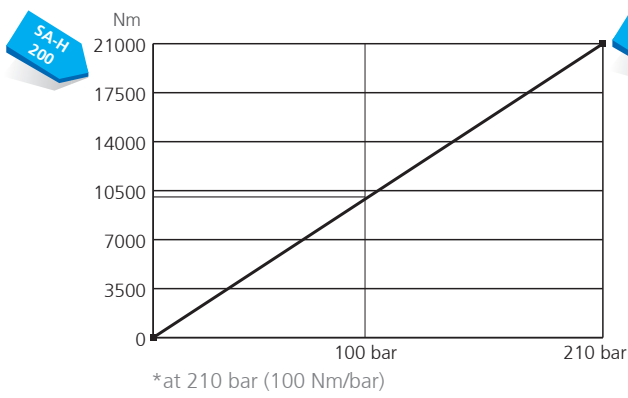
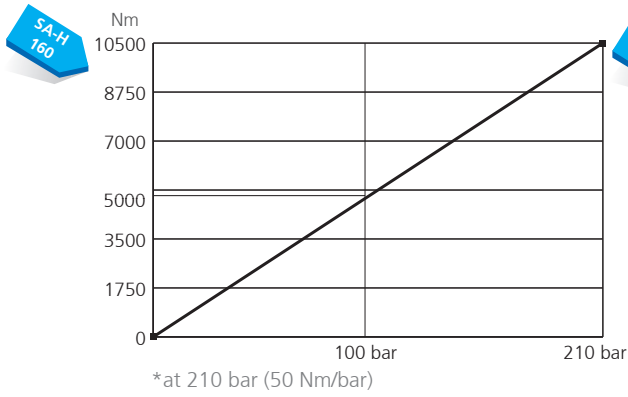

*max. nom. torque

Valve attachment

SA-H and AFR for fittings DIN ISO 5211* (dimensions of flange)

	Ød ₁	Ød ₂ f8	Ød ₃	Ød ₄	h _{max}	Torque
Typ	[mm]	[mm]	[mm]	[mm]	[mm]	[Nm]
F03	46	25	36	M 5	2	32
F04	54	30	42	M 5	2	63
F05	65	35	50	M 6	3	125
F07	90	55	70	M 8	3	250
F10	125	70	102	M 10	3	500
F12	150	85	125	M 12	3	1000
F14	175	100	140	M 16	4	2000
F16	210	130	165	M 20	5	4000
F25	300	200	254	M 16	5	8000
F30	350	230	298	M 20	5	16000
F35	415	260	356	M 30	5	32000
F40	475	300	406	M 36	8	63000
F48	560	370	483	M 36	8	125000
F60	686	470	603	M 36	8	250000

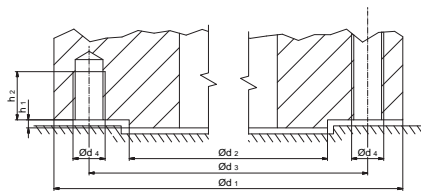

Part-turn actuator

The operating pressures may have to be adjusted in accordance with p. 16/17.

Order Code

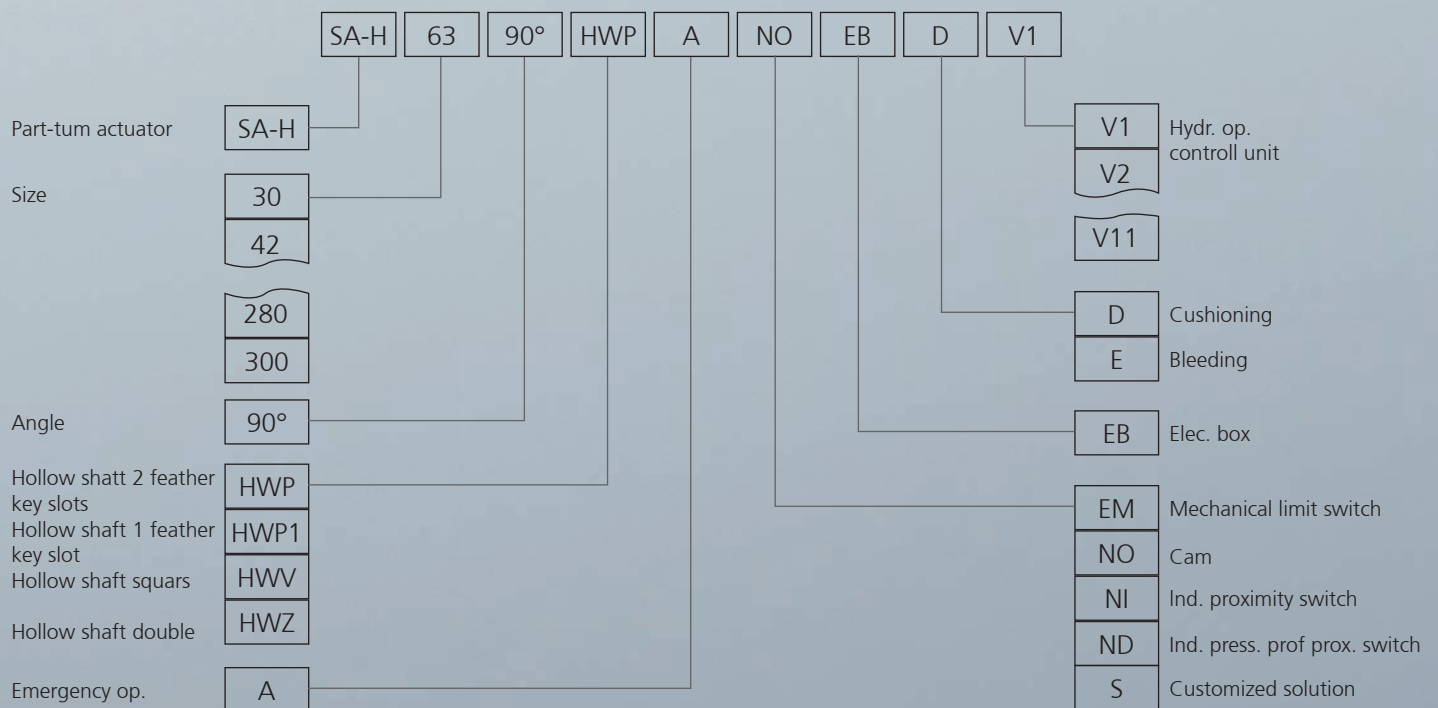

Options

for part-turn actuators
for SA-H and AFR

The versions shown are only a few possibilities of the options with which HKS part-turn actuators can be provided. Our engineers will be pleased to advise you.

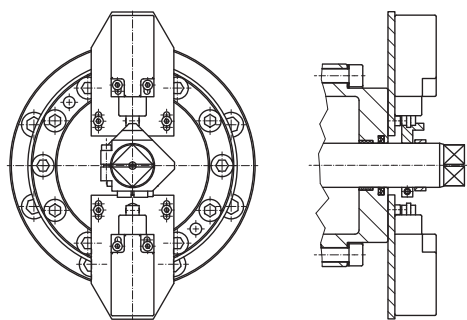

Mechanical limit switch (EM)

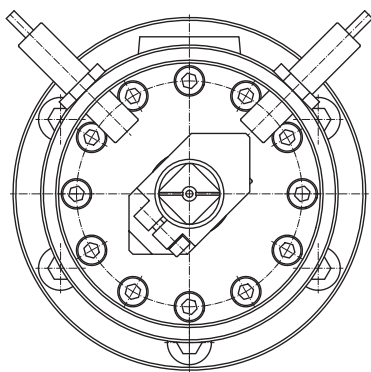

Ind. proximity switch (NI)

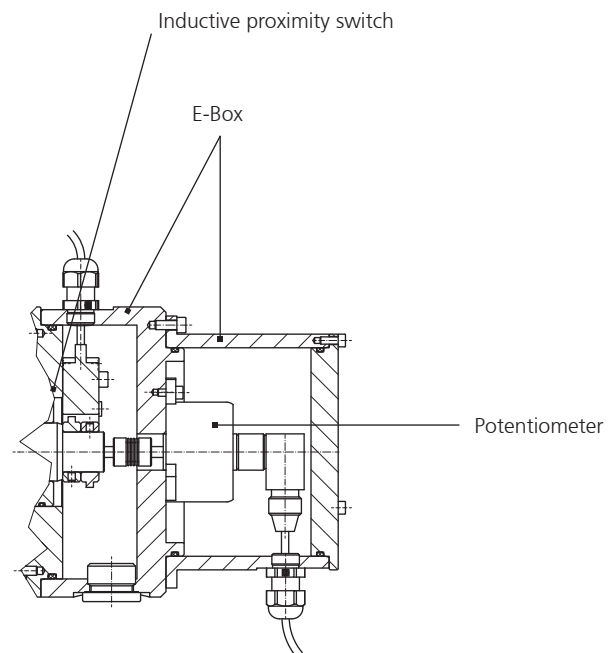

Combination of inductive
proximity switch and
potentiometer in an E-Box

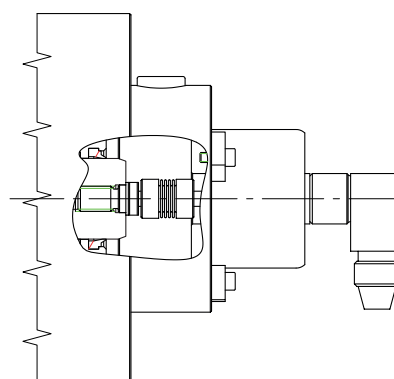

Potentiometer

Hydraulically operated control unit

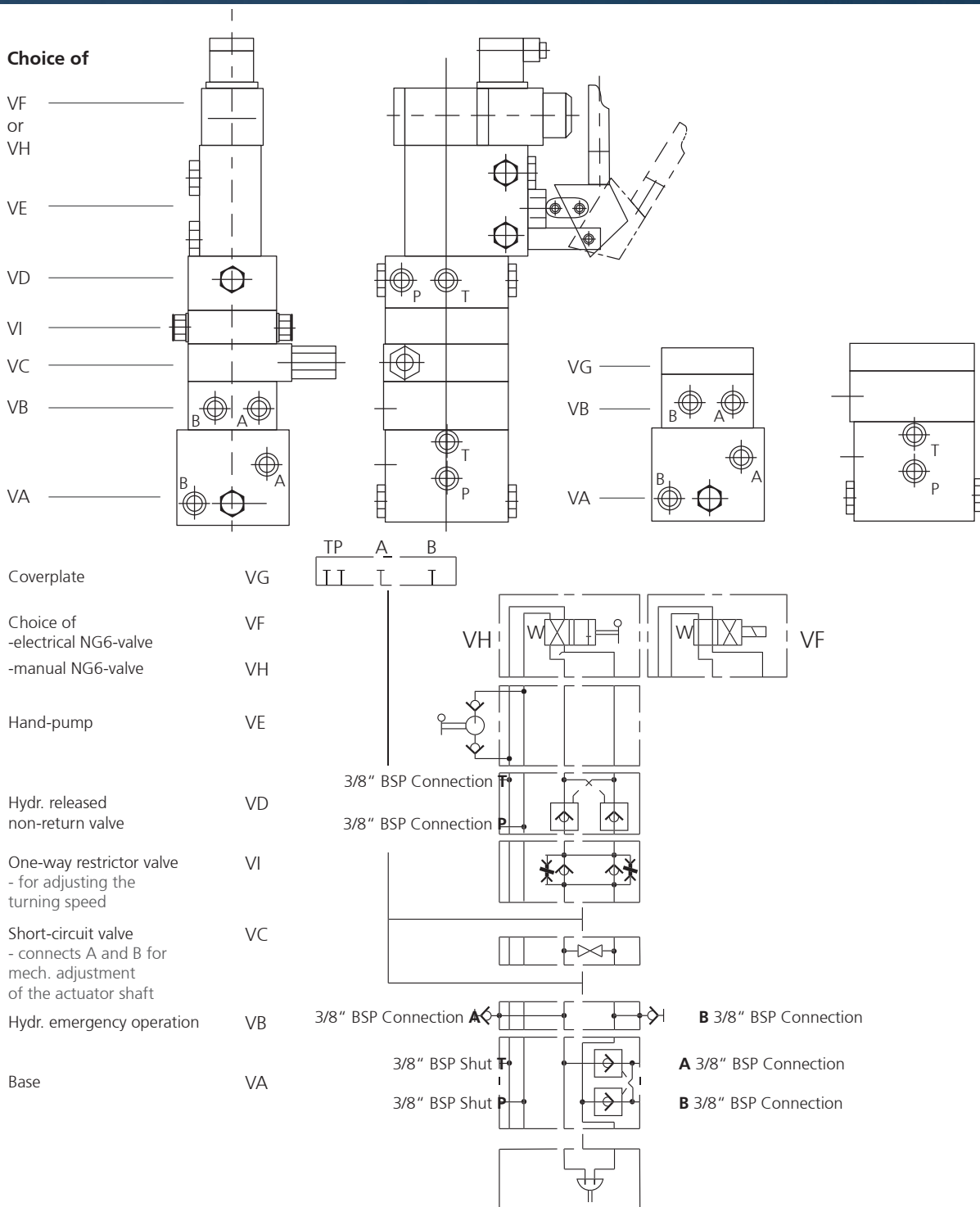

The part-turn actuators can be operated by an external pump aggregate or a hand-pump. Both of these applications are also possible if the hand pump is intended for emergency operation. By operating through an external aggregate there are two possibilities available.

1. The valves are attached to the aggregate
2. All controls are attached to the part-turn actuator

In case 1, connection of the hydraulic pipes is made by the connections A and B. A causes "turning to the left", B. "turning to the right", when looking at the

shaft spigots. In addition to the base VA, the cover-plate VG is required.

In case 2 a ring pipe for P and T from the pump aggregate can supply all actuators, when using several part-turn actuators. Here the pipes for A and B from the aggregate to each part-turn actuator are not required. The connection of the pipes is at P and T in the base VA.

If required the different linked blocks can be combined as a vertical link.

Possibilities of attachment for A and B:

› **Hydraulic emergency operation $V1=VA+VB+VG$**

An additional external pump can be joined either by a screw or a quick-closing coupling to the part-turn actuator.

› **Mechanical emergency operation $V2=VA+VC+VG$**

The shaft can be turned with a square key when the valve is open.

› **Hydraulic and mechanical emergency operation $V3=VA+VB+VC+VG$**

› **Emergency operation with a hand-pump $V4=VA+VB+VC+VG$**

› **All possibilities $V5=VA+VB+VC+VD+VE+VF+VI$ / $V5A=VA+VB+VC+VD+VE+VH+VI$**

Possibilities of connections for P and T:

› **Hydraulic emergency operation $V6=VA+VB+VF$ / $V6A=VA+VB+VH$**

An additional external pump can be joined by a screw or a quick-closing coupling to the part-turn actuator. (pay attention to the right 4/3 directional valve)

› **Mechanical emergency operation $V7=VA+VC+VF$ / $V7A=VA+VC+VH$**

The shaft can be turned with a square key when the valve is open.

› **Hydraulic and mechanical emergency operation $V8=VA+VB+VC+VF$ / $V8A=VA+VB+VC+VH$**

› **Emergency operation with a hand-pump $V4=VA+VD+VE+VF$ / $V4A=VA+VD+VE+VH$**

› **All possibilities $V5=VA+VB+VC+VD+VE+VF+VI$ / $V5A=VA+VB+VC+VD+VE+VH+VI$**

Operating instruction

Tightening torques for cheese head screws DIN EN ISO 4762 (12.9 + Schnorr)

On stainless screws are tightening torques's from the manufacture to inquire. All screws must be lubricated.

Installation and initial operation

The drive shaft is to be aligned properly to the counterpart to avoid exceeding the permissible axial and radial forces. Before initial operation the hydraulic system is to be carefully cleaned and bled.

Pressure fluid

Mineral oils in the group HLP DIN 51524 / Part 2 and VDMA Sheet 24318 are recommended. It must be borne in mind that the viscosity is between 15 mm²/s (cSt.) and 250 mm²/s (cSt.). Hydraulic oils HLP 16 to HLP 46 meet these conditions. Viscosities above and below the required viscosity in the applicable temperature range may result in increased wear.

Flame-resistant hydraulic fluids or bio oils (HFA, HFC and HFD) may only used with our written approval.

Filtration

It is recommended that the pressure fluid be filtered between the pump and rotary actuator (pressure pipe). The hydraulic unit must supply the rotary actuator with a guaranteed oil purity according to NAS 1638 – NAS Class 7. Recommendation filter element: 16 VG. Purity class recommendation: ISO 4406: 1999 (22/18/14).

Oilchange

A change of hydraulic oil is required and depends on the size of the system. In smaller systems an oil change is required at correspondingly shorter intervals. If the hydraulic fluid is contaminated it must be changed immediately.

Oil replacement

In the case of long oil pipes, there should be a guarantee that 50% of the displacement will be replaced for one complete slewing movement.

Temperature range

-10°C to +75°C

If the thermal load is higher or lower than this range, consult the factory

Before installation

Fit the screw connections with the correct tightening torques. Otherwise the loading capacity of the connection will be reduced. If this is the case the connection will loosen.

Company:		Tel.:	
Name:		Fax.:	
Street:		E-Mail:	
Code / City:		Web:	

Project:	Commission:	Responsible:	Date:
----------	-------------	--------------	-------

1 Type of valve Ball valve Flaps Other _____

2 Various connection

<input type="checkbox"/> HWP 	<input type="checkbox"/> HWP 1 	<input type="checkbox"/> HWV 	<input type="checkbox"/> HWZ
----------------------------------	------------------------------------	----------------------------------	----------------------------------

2.1 Dimensions $\varnothing X1$: X2: X3: SW V: SW Z: $\varnothing Z1$:

3 ISO-Flange

<input type="checkbox"/> F03	<input type="checkbox"/> F04	<input type="checkbox"/> F05	<input type="checkbox"/> F07	<input type="checkbox"/> F10	<input type="checkbox"/> F12	<input type="checkbox"/> F14	<input type="checkbox"/> F16	<input type="checkbox"/> F25	<input type="checkbox"/> F30	<input type="checkbox"/> F35	<input type="checkbox"/> F40	<input type="checkbox"/> F48	<input type="checkbox"/> F60	<input type="checkbox"/> with screw:
													<input type="checkbox"/> with through hole:	

3.1 Alternative Flange _____ (Please attach a drawing)

4 Required nom. torque	M		Nm
5 Part-turn angle			°
5.1 Part-turn time	t		s
5.2 Cycles	Z		day/week

6 Hydraulic plant

6.1 Effective working pressure	p1		bar
6.2 Max. perm. system pressure	p2		bar
6.3 Flow rate	Q		l/min.
6.4 Plant temperature	TA		°C
6.5 Surrounding temperature	TU		°C
6.6 Medium used			

7 Special conditions of use _____

8 Conditions at working place _____

9 Necessary properties of part-turn actuator _____

10 Additional equipment required

<input type="checkbox"/> Emergency operation	<input type="checkbox"/> Cushioning
<input type="checkbox"/> Mechanical limit switch	<input type="checkbox"/> Adjustment of the rotation angle
<input type="checkbox"/> Induced pressure proof proximity switch	<input type="checkbox"/> Hydraulically operated control unit
<input type="checkbox"/> Induced proximity switch	<input type="checkbox"/> SIL II
<input type="checkbox"/> Electrical-box	<input type="checkbox"/> ATEX Class: _____
<input type="checkbox"/> Bleeding	<input type="checkbox"/> Other: _____

11 Single action spring return

<input type="checkbox"/> Spring return load	<input type="checkbox"/> N
<input type="checkbox"/> See 1-10	

12 Recommended actuator _____



Our highly qualified designers develop efficient HKS products for their customers, equipped with state-of-the-art hardware and software applications. In cooperation with you as our customer and with our experienced technical customer support team, we develop high-quality HKS products tailored to suit your needs.



From a logistics viewpoint the HKS Group plant 1 is located in the centre of the EU regionally linked to Europe's biggest cargo airport and also within easy reach of the biggest freight ports of Rotterdam and Hamburg. Our plant 2 is in a strategically convenient location for the Eastern European market.

Die HKS Dreh-Antriebe GmbH®

The HKS Dreh-Antriebe GmbH is one of the world's leading manufacturer of rotary actuators, tilt rotators, rotary lift combinations and as well rack and pinion rotary actuators. Besides cylinders HKS distributes vane actuators and since 2012 medical training equipment. The family business, founded in 1970 currently employs approximately 190 employees at 3 sites in Germany.

With sales partners in over 20 countries, HKS Dreh-Antriebe GmbH is internationally oriented. The proportion of sales to foreign countries is over 50%.





As a family business, HKS Dreh-Antriebe GmbH attaches great importance to responsible and long-term actions. Sustainability, community involvement and health promotion of employees in the context of numerous health actions some of the key points in the company's principles.



www.hks-partner.com



Scan me 

-  facebook.com/HKSDrehAntriebe
-  twitter.com/HKSDrehAntriebe
-  youtube.com/HKSDrehAntriebe
-  issuu.com/hks_

HKS Dreh-Antriebe GmbH® • Leipziger Straße 55 • 63607 Wächtersbach-Aufenu • Germany • fon: +49 6053 6163-0 • fax: +49 6053 6163-639

Copyright 2016 HKS Dreh-Antriebe GmbH®
DIN EN ISO 9001:2008 TÜV certified
Illustrations similar. Information no liability assumed.
Subject to alteration.
Status: 11/2016

